

COMPOSITION BOOK COVER

FROM SUSAN STRUMPF

Make a cover using up leftover blocks and scraps from your quilt projects. This cover fits a standard size composition notebook (9.75 x 7.5") which can be easily replaced when its time for a new notebook!

Fabric requirements:

Fusible Fleece measuring 16.75" x 11"

Outside cover – you will need fabric measuring approximately 16.75" x 11"

Lining – two pieces measuring 7.5" x 11" and one piece measuring 5" x 11"

Binding – 2.5" strips measuring approximately 60" in length, pressed in half



Covers shown here in Tulip Tango fabrics.

Create a composition book cover:

Create your cover (exterior panel)– it can be as simple as a single fabric that you want to feature, or it can incorporate piecing or appliqué. When designing your cover, keep in mind that the midpoint of the cover, where it will fold in half, will be at about 8 3/8" (so 8.25 - 8.5" is shown as a dashed line area for reference.)

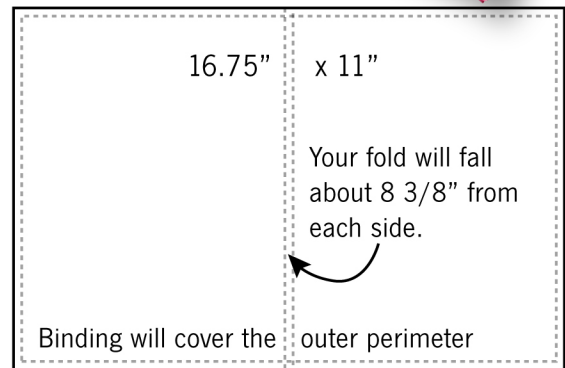

Shown below are 2 layouts for ROUGH ideas and measures. The sizes listed here were CUT size, not finished size. Use your scraps to have fun and create your own composition!

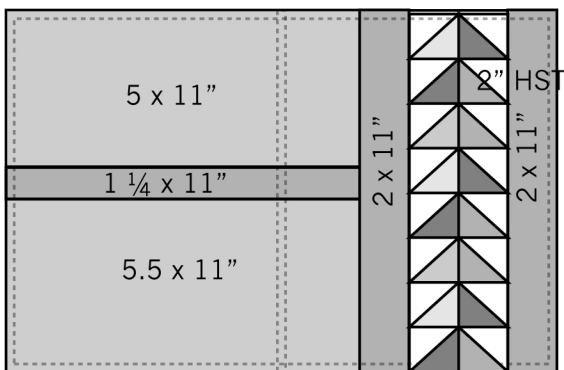

OR

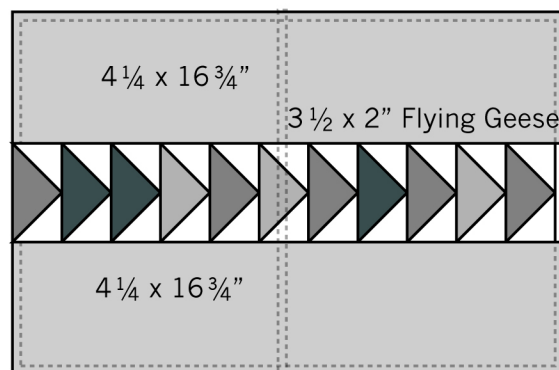

When the exterior cover composition is complete, fuse your exterior fabric (approximately 16.75" x 11") to the fusible fleece. Trim as needed to 'square up' your rectangle. Add machine quilting, as desired.

Place exterior panel right side down. Place the 5" x 11" piece of lining fabric right side up, in the center of the fleece.

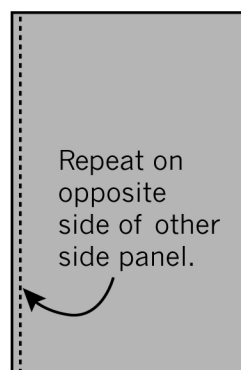
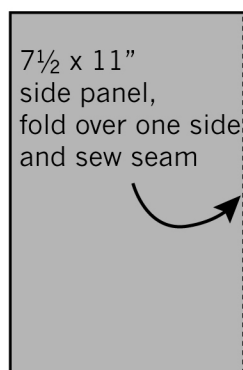
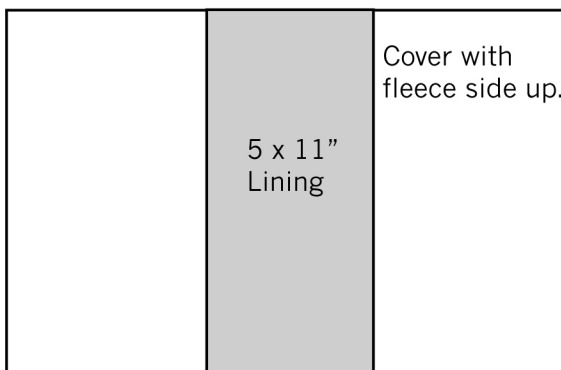

On both side panels (measuring 7.5" x 11"), turn under one 11" edge and press. Top stitch if desired with a straight stitch or a decorative stitch.

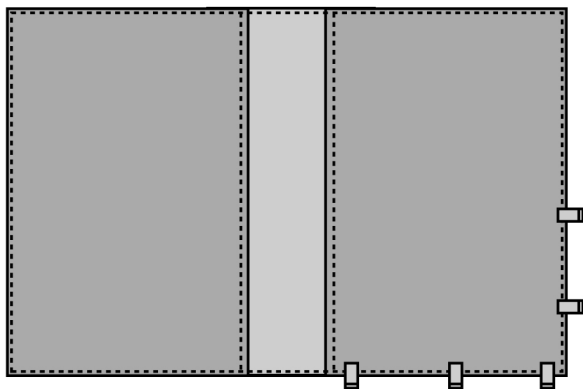

Place these side panels right side up against the side edges of the fleece, with folded/sewn edge towards center. Pin or clip then machine baste the entire perimeter, 1/8" from edge. Attach prepared binding around perimeter of cover.

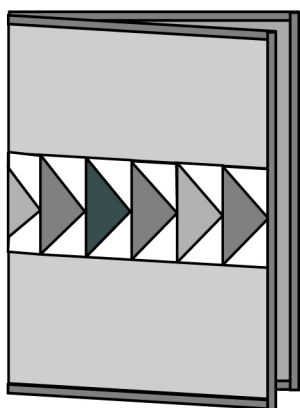

Insert composition book – lined paper or graph paper.
Enjoy!

These are some other ideas for the Composition Book Covers. Experiment with applique, leftover quilt blocks, patchwork or a memory notebook with pieces of treasured neckties.



Susan Strumpf has been stitching for many years and enjoys the creative process of working with textiles. Piecing quilts, stitching cotton and wool appliqué, and creating texture and dimension with embroidery are just a few of her interests. She teaches classes and workshops at the Quilt Emporium in Woodland Hills, CA.

This pattern is available through Robin Pickens shop, www.RobinPickensINC.com. Robin has been the lucky quilter whom Susan has made numerous samples for. Thank you Susan for making this versatile pattern available!

This pattern is ©2022 Susan Strumpf. Please credit Susan Strumpf as the designer of this pattern when posting and sharing photos of your composition covers made with this pattern. Permission needs to be granted by Susan Strumpf before any publishing of pattern or mass distribution. Please contact susanstrumpf@gmail.com.

This pattern can be found at www.RobinPickensINC.com in "FREEBIES" section of the shop for digital download for your own use.